

Face Milling ● General Face Milling

MFB145/245
Double-sided 45° General Face Milling-MFB145/245

MFB145

Arbor

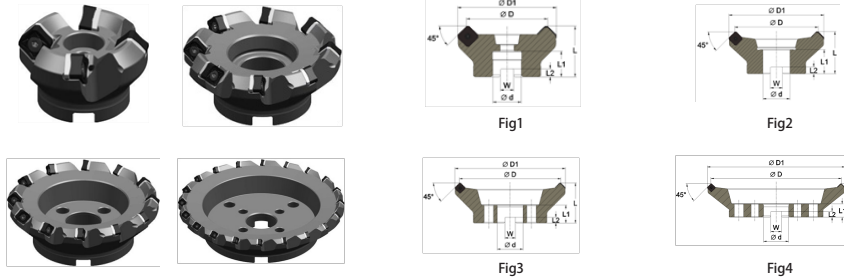

Coarse Pitch

Ordering Code		Teeth	(mm) Dimensions					Ap	Gauge Insert	Shim	Inner-	Shape	Stock
			ΦD	L	Φd	W	L2						
MFB145050R03A22SN12	50	3	50	40	22	10.4	6.3	5	SNEU1206	✓	✓	Fig1	●
MFB145063R04A22SN12	63	4	63	40	22	10.4	6.3	5	SNEU1206	✓	✓	Fig1	●
MFB145080R05A27SN12	80	5	80	50	27	12.4	7.0	5	SNEU1206	✓	✓	Fig1	●
MFB145100R06B32SN12	100	6	100	50	32	14.4	8.0	5	SNEU1206	✓	x	Fig2	●
MFB145125R07B40SN12	125	7	125	63	40	16.4	9.0	5	SNEU1206	✓	x	Fig2	○
MFB145160R08C40SN12	160	8	160	63	40	16.4	9.0	5	SNEU1206	✓	x	Fig3	○
MFB145200R10C60SN12	200	10	200	63	60	25.7	14	5	SNEU1206	✓	x	Fig3	○
MFB145250R12C60SN12	250	12	250	63	60	25.7	14	5	SNEU1206	✓	x	Fig3	○
MFB145315R15D60SN12	315	15	315	63	60	25.7	14	5	SNEU1206	✓	x	Fig4	○

● Stock ○ Available upon Order

Close Pitch

Ordering Code		Teeth	(mm) Dimensions					Ap	Gauge Insert	Shim	Inner-	Shape	Stock
			ΦD	L	Φd	W	L2						
MFB145050R04A22SN12	50	4	50	40	22	10.4	6.3	5	SNEU1206	✓	✓	Fig1	●
MFB145063R05A22SN12	63	5	63	40	22	10.4	6.3	5	SNEU1206	✓	✓	Fig1	●
MFB145080R07A27SN12	80	7	80	50	27	12.4	7.0	5	SNEU1206	✓	✓	Fig1	●
MFB145100R08B32SN12	100	8	100	50	32	14.4	8.0	5	SNEU1206	✓	x	Fig2	●
MFB145125R10B40SN12	125	10	125	63	40	16.4	9.0	5	SNEU1206	✓	x	Fig2	●
MFB145160R12C40SN12	160	12	160	63	40	16.4	9.0	5	SNEU1206	✓	x	Fig3	●
MFB145200R14C60SN12	200	14	200	63	60	25.7	14	5	SNEU1206	✓	x	Fig3	●
MFB145250R16C60SN12	250	16	250	63	60	25.7	14	5	SNEU1206	✓	x	Fig3	●
MFB145315R20D60SN12	315	20	315	63	60	25.7	14	5	SNEU1206	✓	x	Fig4	●

● Stock ○ Available upon Order

/continued on next page

Face Milling ● General Face Milling

Double-sided 45° General Face Milling-MFB145/245

MFB145

Arbor

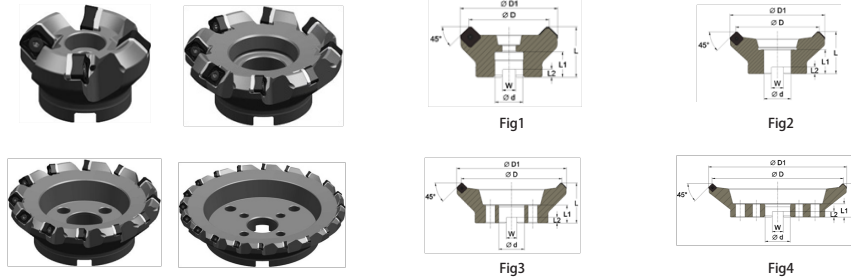





Extra Close Pitch

Ordering Code		Teeth	(mm) Dimensions					Ap	Gauge Insert	Shim	Inner-	Shape	Stock
			ØD	L	Ød	W	L2						
MFB145050R05A22SN12	50	5	50	40	22	10.4	6.3	5	SNEU1206	✓	✓	Fig1	●
MFB145063R06A22SN12	63	6	63	40	22	10.4	6.3	5	SNEU1206	✓	✓	Fig1	●
MFB145080R08A27SN12	80	8	80	50	27	12.4	7.0	5	SNEU1206	✓	✓	Fig1	●
MFB145100R10B32SN12	100	10	100	50	32	14.4	8.0	5	SNEU1206	✓	x	Fig2	●
MFB145125R12B40SN12	125	12	125	63	40	16.4	9.0	5	SNEU1206	✓	x	Fig2	○
MFB145160R15C40SN12	160	15	160	63	40	16.4	9.0	5	SNEU1206	✓	x	Fig3	○
MFB145200R18C60SN12	200	18	200	63	60	25.7	14	5	SNEU1206	✓	x	Fig3	○
MFB145250R21C60SN12	250	21	250	63	60	25.7	14	5	SNEU1206	✓	x	Fig3	○
MFB145315R24D60SN12	315	24	315	63	60	25.7	14	5	SNEU1206	✓	x	Fig4	○

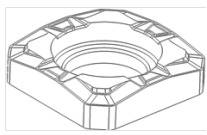
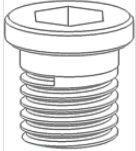
● Stock ○ Available upon Order

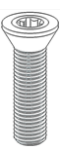
Spare Parts

Shim (DSN1206M)	Shim Screw (SSAM6X8F)	L Type Wrench (TH40L)	Insert Screw (SI60M4X15)	Insert Spanner (TT15P)
				
H0K40SSN12	730100910075	720301260456	730100961150	720300960510

Face Milling ● General Face Milling

Double-sided 45° General Face Milling-MFB145/245

MFB245

Arbor

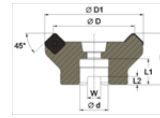

Fig1

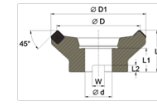

Fig2

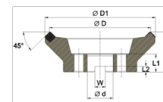

Fig3

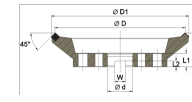

Fig4

Coarse Pitch

Ordering Code		Teeth	(mm) Dimensions					Ap	Gauge Insert	Shim	Inner-	Shape	Stock
			ϕD	L	ϕd	W	L2						
MFB245050R03A22SN12	50	3	50	40	22	10.4	6.3	5	SNEU1206	x	✓	Fig1	●
MFB245063R04A22SN12	63	4	63	40	22	10.4	6.3	5	SNEU1206	x	✓	Fig1	●
MFB245080R05A27SN12	80	5	80	50	27	12.4	7.0	5	SNEU1206	x	✓	Fig1	●
MFB245100R06B32SN12	100	6	100	50	32	14.4	8.0	5	SNEU1206	x	x	Fig2	●
MFB245125R07B40SN12	125	7	125	63	40	16.4	9.0	5	SNEU1206	x	x	Fig2	○
MFB245160R08C40SN12	160	8	160	63	40	16.4	9.0	5	SNEU1206	x	x	Fig3	○
MFB245200R10C60SN12	200	10	200	63	60	25.7	14	5	SNEU1206	x	x	Fig3	○
MFB245250R12C60SN12	250	12	250	63	60	25.7	14	5	SNEU1206	x	x	Fig3	○
MFB245315R15D60SN12	315	15	315	63	60	25.7	14	5	SNEU1206	x	x	Fig4	○

● Stock ○ Available upon Order

Close Pitch

Ordering Code		Teeth	(mm) Dimensions					Ap	Gauge Insert	Shim	Inner-	Shape	Stock
			ϕD	L	ϕd	W	L2						
MFB245050R04A22SN12	50	4	50	40	22	10.4	6.3	5	SNEU1206	x	✓	Fig1	●
MFB245063R05A22SN12	63	5	63	40	22	10.4	6.3	5	SNEU1206	x	✓	Fig1	●
MFB245080R07A27SN12	80	7	80	50	27	12.4	7.0	5	SNEU1206	x	✓	Fig1	●
MFB245100R08B32SN12	100	8	100	50	32	14.4	8.0	5	SNEU1206	x	x	Fig2	●
MFB245125R10B40SN12	125	10	125	63	40	16.4	9.0	5	SNEU1206	x	x	Fig2	●
MFB245160R12C40SN12	160	12	160	63	40	16.4	9.0	5	SNEU1206	x	x	Fig3	●
MFB245200R14C60SN12	200	14	200	63	60	25.7	14	5	SNEU1206	x	x	Fig3	●
MFB245250R16C60SN12	250	16	250	63	60	25.7	14	5	SNEU1206	x	x	Fig3	●
MFB245315R20D60SN12	315	20	315	63	60	25.7	14	5	SNEU1206	x	x	Fig4	●

● Stock ○ Available upon Order

/continued on next page

Face Milling ● General Face Milling

Double-sided 45° General Face Milling-MFB145/245

MFB245

Arbor

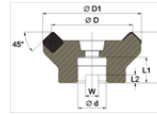
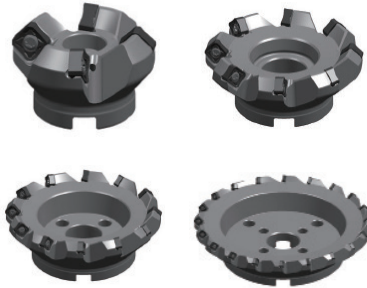

Fig1

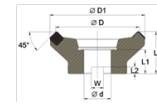

Fig2

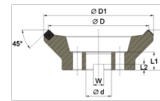

Fig3

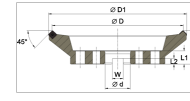

Fig4

Extra Close Pitch

Ordering Code		Teeth	(mm) Dimensions					Ap	Gauge Insert	Shim	Inner-	Shape	Stock
			ϕD	L	ϕd	W	L2						
MFB245050R05A22SN12	50	5	50	40	22	10.4	6.3	5	SNEU1206	x	✓	Fig1	●
MFB245063R06A22SN12	63	6	63	40	22	10.4	6.3	5	SNEU1206	x	✓	Fig1	●
MFB245080R08A27SN12	80	8	80	50	27	12.4	7.0	5	SNEU1206	x	✓	Fig1	●
MFB245100R10B32SN12	100	10	100	50	32	14.4	8.0	5	SNEU1206	x	x	Fig2	●
MFB245125R12B40SN12	125	12	125	63	40	16.4	9.0	5	SNEU1206	x	x	Fig2	○
MFB245160R15C40SN12	160	15	160	63	40	16.4	9.0	5	SNEU1206	x	x	Fig3	○
MFB245200R18C60SN12	200	18	200	63	60	25.7	14	5	SNEU1206	x	x	Fig3	○
MFB245250R21C60SN12	250	21	250	63	60	25.7	14	5	SNEU1206	x	x	Fig3	○
MFB245315R24D60SN12	315	24	315	63	60	25.7	14	5	SNEU1206	x	x	Fig4	○

● Stock ○ Available upon Order

Spare Parts

Insert Screw
(S160M5X14)

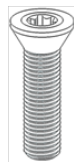

730100961212

Insert Spanner
(TT20P)

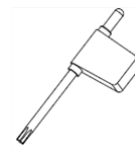





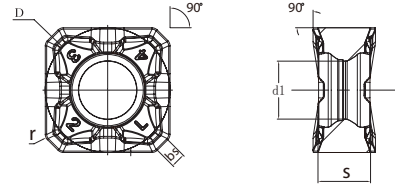

720300960515

Face Milling ● General Face Milling

Insert

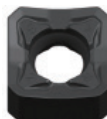







SNEU

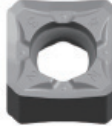

Ordering Code	Dimensions(mm)					Coated					Uncoated				Cermet
	D	S	bs	d1	r	A4225	A4230	M2125	K2115	K4125	A0115	P0135	K0115	N9125	P01TM
NEW  SNEU1206ANEN-GL	12.7	6.35	2.2	6.0	0.8	●	●	○	●	●					
NEW  SNEU1206ANEN-GM	12.7	6.35	2.2	6.0	0.8	●	●	○	●	●					
NEW  SNEU1206ANSN-GH	12.7	6.35	2.2	6.0	0.8	●	●		●	●					
NEW  SNEU1206ANFN-NL	12.7	6.35	2.2	6.0	0.8									●	
NEW  SNEU1206ANEN-GW	12.7	6.35	5.6	6.0	0.8	●	●		●	●					

● Stock ○ Available upon Order

SNEU SNEU Series Geometry

GL Geometry	GM Geometry	GH Geometry	NL Geometry	GW
				
				
Light Cutting for General material	Medium Cutting for General material	Rough Cutting for general material	General cutting for aluminum alloys	Wiper insert
Special edge shape with big rake angle and narrow edge width. Machining general material with low force and low feed.	Design with medium rake angle and edge width. Combine Sharp with strength. Medium machining general material under general working conditions.	Small rake and big edge width with negative chamfer land improve edge strength. Heavy machining general material with big depth of cut, available for strong interruption machining too.	Sharp edge, larger rake angle and mirror polishing contribute to low cutting force and evacuation of chip. Suitable for general milling of Non-Ferrous Metal, such as aluminum, copper, etc.	Unique wiper edge contributes to high quality of surface finish and the improvement of feed. High quality surface finish can be achieved.

Recommended Cutting Data

Workpiece Materials	Materials Hardness	Grade	(mm/min) Recommended Cutting Speed	Light Cutting		Medium Cutting		Heavy Cutting	
				(mm/ tooth)	Geometry	(mm/ tooth)	Geometry	(mm/ tooth)	Geometry
P Low Carbon Steel (S45C, S10C)	≤ HB180	A4230 A4225	250 (200-300)	0.15 (0.1-0.2)	GL	0.2 (0.1-0.3)	GM	0.3 (0.2-0.4)	GH
	HB180-280	A4230 A4225	220 (170-270)	0.15 (0.1-0.2)	GL	0.2 (0.1-0.3)	GM	0.3 (0.2-0.4)	GH
		A4230	150 (100-200)	0.12 (0.1-0.15)	GL	0.15 (0.1-0.2)	GM	0.2 (0.15-0.25)	GH
M Stainless Steel (SUS304)	≤ HB280	A4230 A4225	180 (130-250)	0.15 (0.1-0.2)	GL	0.2 (0.1-0.3)	GM	--	--
K Gray Cast Iron Nodular Cast Iron (FC250, FCD400)	≤ HB350	A4230 A4225	180 (130-250)	0.15 (0.1-0.2)	GL	0.2 (0.1-0.3)	GM	0.3 (0.2-0.4)	GH
N Aluminum	HB60-210	N9125	800 (300-1000)	0.15 (0.1-0.2)	NL	0.2 (0.1-0.3)	NL	--	--
S Heat-resistant Alloy	HRC25-35	A4230	40 (20-50)	0.05 (0.05-0.1)	GL	0.1 (0.05-0.15)	GM	--	--

★ Tool RPM (min⁻¹) = (1000xCutting Speed) ÷ (3.14x Diameters of Cutter)

★ Workpiece Feed (mm/min) = Feed Per Tooth x Number of Tooth x Tool RPM